

Cut-out Details

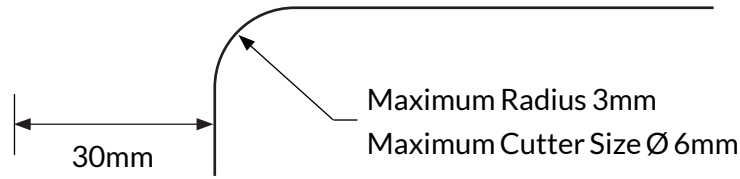

*Leave 30mm clearance from edge of cut out - Required for Step 4 and Removal.

- 1 Set Clamp Arms to suit table thickness.

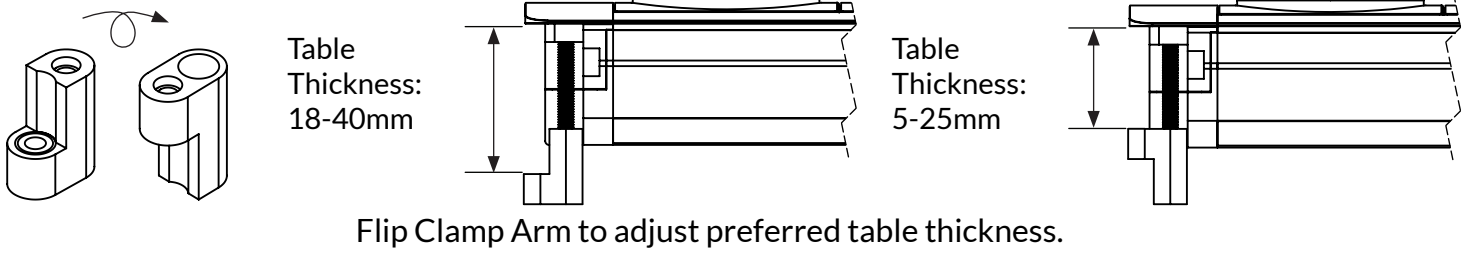

- 2 For surface thickness less than 5mm.
Fit bumpers to underside of frame to increase surface thickness.

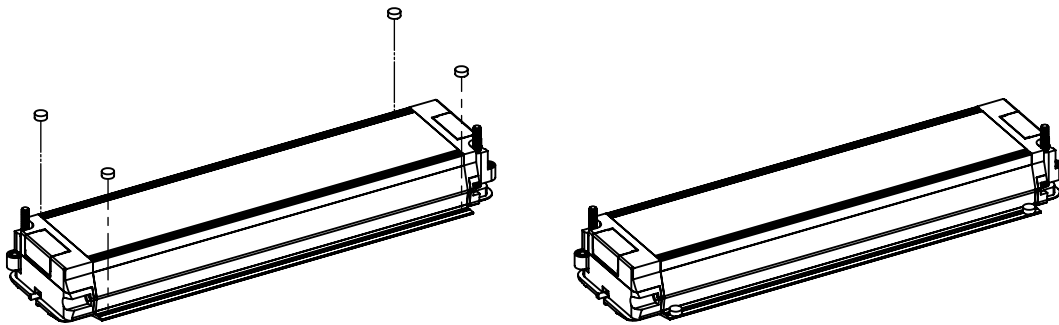

- 3 Make sure clamp arms are folded inwards and position Mirage unit into desk cut out.

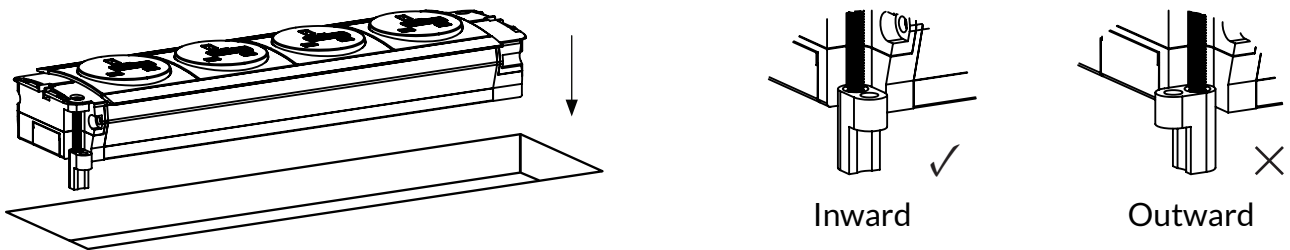

- 4 Tighten the screws.

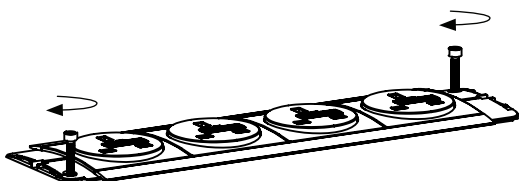

- 4 Slide Toppers onto the module endcaps.

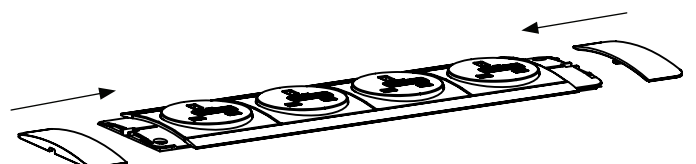

Removal

- 1 Fully insert Removal Toll to the side.



- 2 Pull Toppers out with Removal Tool and unscrew screws to disassemble from cut out.

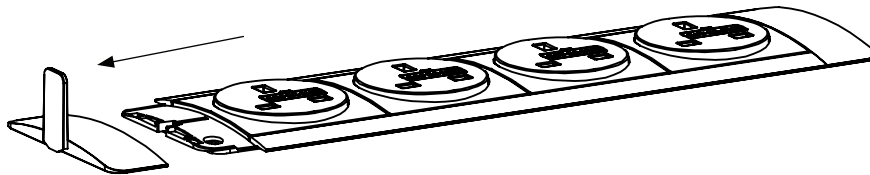

Dimensions:

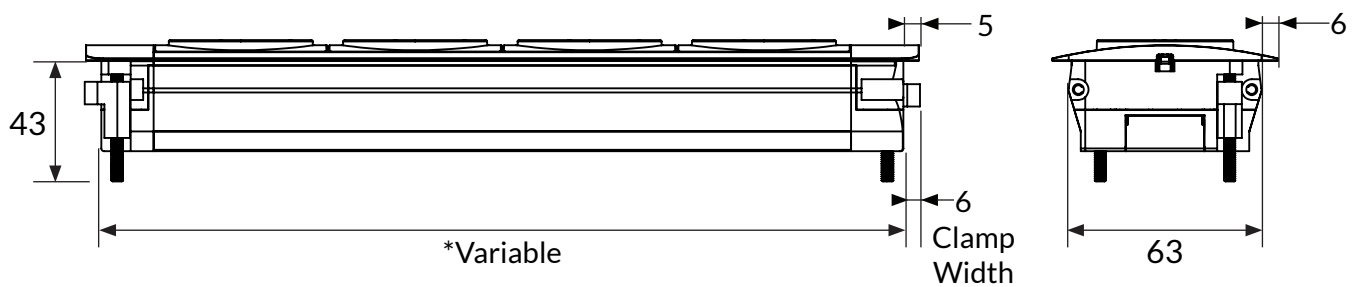

*All measurements in mm